

ACS 100 and ACS 140

**Instruction Sheet**

ACS 100 and ACS 140  
NEMA 1 Enclosure Kit



## Introduction

The ACS 100 and ACS 140 NEMA 1 Enclosure Kit provides a NEMA 1 housing for the ACS 100 and ACS 140 IP 20 protected chassis units. The NEMA 1 enclosure kit consists of a metal back plate with a conduit plate and a plastic cover. The drive heatsink is flange mounted to the back plate so that the heatsink fins are outside the enclosure. The assembled NEMA 1 drive unit can be mounted to a vertical surface using a DIN rail or the mounting holes and slots in the heatsink.

## Planning for Mounting the Assembled Unit

The final mounting of the drive should be planned before installing the drive in the enclosure kit. Refer to the outline and mounting dimension drawing and/or use the drive or the backplate as a template to locate the mounting holes. Note that the drives of frame size A have limited clearance for access to the mounting bolts. Hex head mounting bolts or nuts must be tightened by reaching behind the back plate with a wrench. Bolts or screws with a screwdriver or allen head can be tightened by inserting a screwdriver or allen wrench through clearance holes in the back plate.

## Assembling the Kit

To assemble the kit, perform the following steps

The kit contains two backplates as shown in Figure 1. The backplate with the smaller rectangular hole is used for drives of frame size A, B and D. The other one is used for drives of frame size D. For Drives of frame size C, the smaller rectangular hole must be enlarged by removing the knock-out section.

Insert the drive heatsink through the rectangular hole in the backplate of the NEMA 1 kit as shown in Figure 2.

Tilt the drive chassis forward and insert the bottom of the heatsink. Move the chassis downward and insert the top of the heatsink.

Move the heatsink through the backplate until the heatsink flange rests against the surface of the backplate.

Fasten the heatsink flange to the backplate using four (4) M4 bolts.

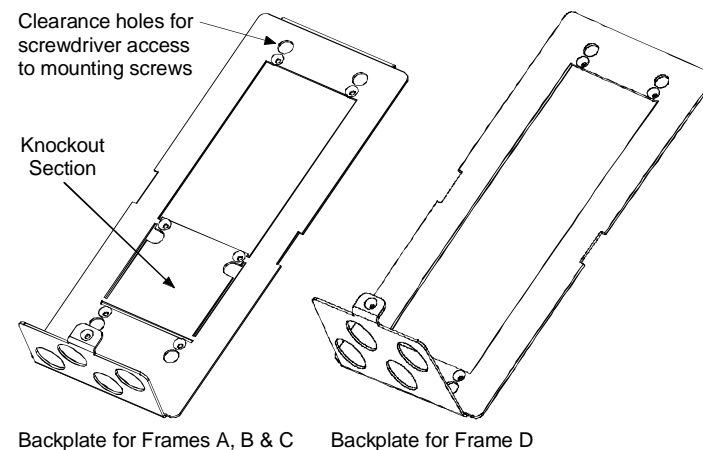
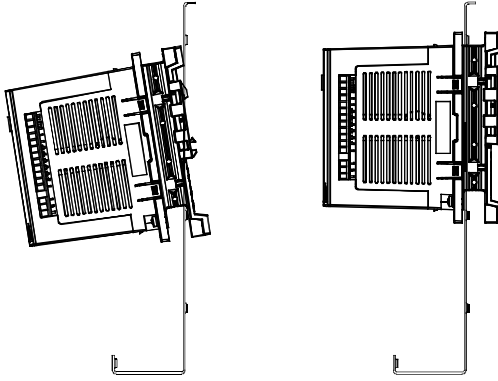

Figure 1 Backplates



*Figure 2 Inserting the Drive into the Backplate*

***Mounting the Assembled Unit***

Mount the drive to a vertical surface using No. 8 (4 mm) screws or bolts inserted through the holes and slots in the drive heatsink. Hex head mounting bolts or nuts must be tightened by reaching behind the back plate with a wrench. Bolts or screws with a screwdriver or allen head can be tightened by inserting a screwdriver or allen wrench through clearance holes in the back plate. See Figure 2.

Complete the installation by connecting conduit to the conduit plate and installing the wiring.

***Installing the Cover and Keypad***

Remove the keypad from the drive if it has been installed. Refer to the ACS 100 or ACS 140 User's Guide. Pull forward on the top of the keypad and tilt it forward until it unplugs from the drive. Lift the keypad from the hook at the bottom. Set the keypad aside.

Remove the cover from the drive. Refer to the ACS 100 or ACS 140 User's Guide. Simultaneously press the four (4) snap-on buttons in the top and bottom corners of the unit and pull the cover forward. Discard the cover.

Install the cover of the NEMA 1 kit. Hook the top of the cover over the top of the back plate. Push the cover against the drive chassis. Make sure that the raised panel around the keypad plug fits into the square hole in the cover. Fasten the cover with an M4 screw inserted through the hole at the bottom of the cover.

Install the keypad by hooking it over the hook at the bottom and tilting it back so that it plugs into the drive.

# DIMENSIONS

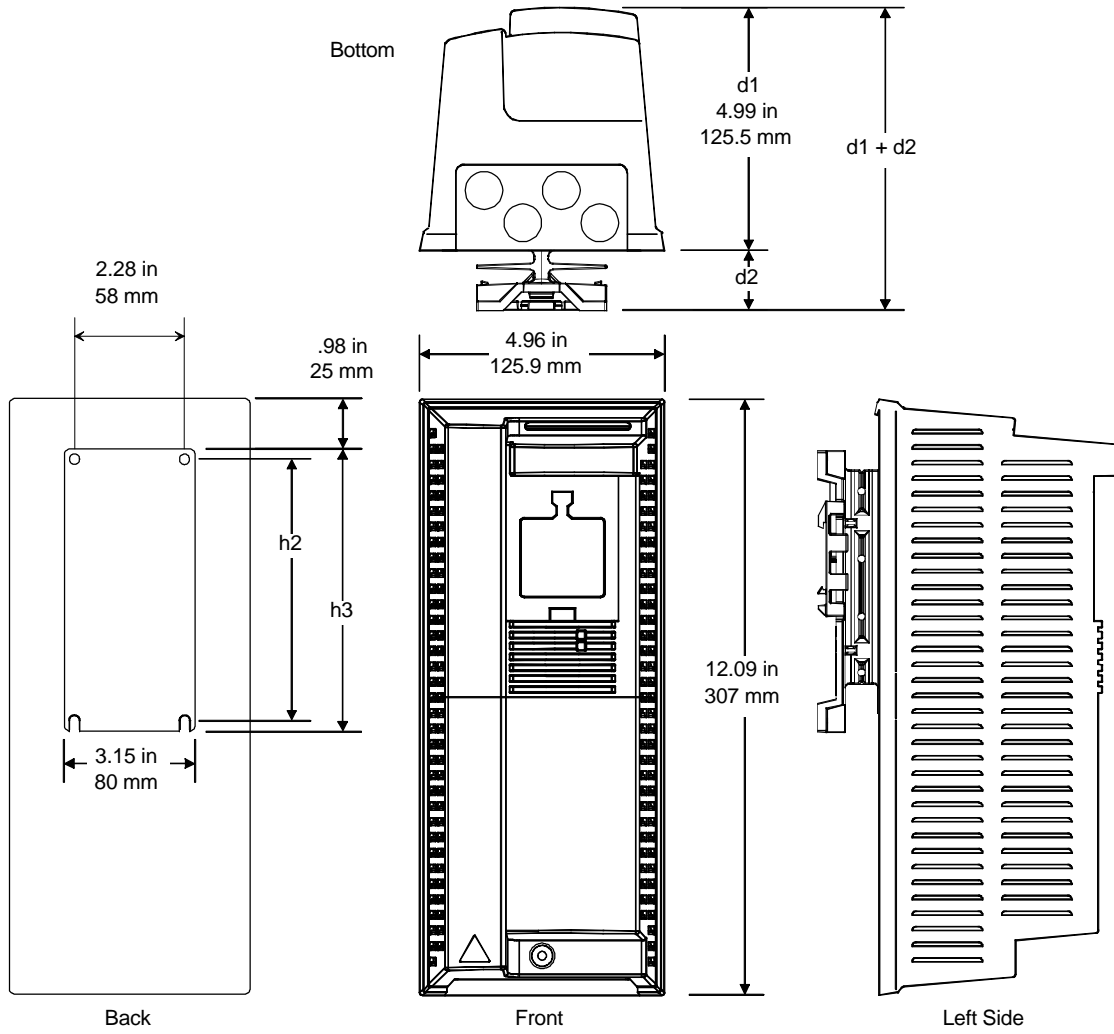

ABB Industrial Systems, Inc.  
16250 W. Glendale Drive  
New Berlin, WI 53151

Telephone: (414) 785-8378  
(800) 243-4384  
Fax: (414) 780-5135

NEMA1-US-11  
3AUA489002B5250 R0101 REV A  
EFFECTIVE 2/8/99  
SUPERCEDES: NONE